

URBANCHAIN

Parking & mobility infrastructure



URBANCHAIN

UrbanChain Group is a leading provider of smart parking and mobility solutions, with thousands of installations across the globe. As an innovator in the industry, we specialize in integrating AI and IoT technologies to transform urban mobility and parking management. Founded in 2018 in Hong Kong, UrbanChain Group is has a robust presence through subsidiaries and certified partners worldwide.

Our cutting-edge solutions are designed to enhance efficiency and convenience for both drivers and operators. Focusing on adaptability and daily operational needs, our systems provide seamless and user-friendly experiences, significantly contributing to the ease of urban mobility.

UrbanChain Group's state-of-the-art manufacturing and quality control facilities are strategically located to ensure the highest standards in production and service delivery. We collaborate closely with our partners in various regions to meet the specific needs of our clients, ensuring personalized and effective solutions.

At UrbanChain Group, we prioritize innovation over mass production. Our dedicated project management teams ensure swift implementation, while continuous customer consultations drive the ongoing enhancement of our products and services. In essence, we are committed to pioneering advancements rather than merely following industry trends.



AVR AI Camera

Our Automated Vehicle Recognition (AVR) cameras powered with AI are capable to identify license plate numbers in over 90 countries with 99% average accuracy rate. In addition, our algorithm recognizes vehicle type, color and brand name with 80% average accuracy. We have 3 key models for various indoor and outdoor settings.

CHARACTERISTICS:

- ▶ Recognition of standard and non standard car plates, vehicle types, vehicle colors, car makes;
- ▶ Other recognition tasks can be implemented (i.e. EV vs fuel car, recognition of people's age, gender, role);
- ▶ Recognition of car plates in tough conditions, s.a. high light beams, direct sunlight, raining, darkness, dirty/damaged car plates, multiple car plates at the same time (i.e. HK, cross-border, Macau)

OPTIONS:

- ▶ Stereo Edge AVR camera, color and design can be customized;
- ▶ AVR network PTZ camera with full remote control (IR/non-IR, PoE or WiFi);
- ▶ AVR extra-zoom network PTZ camera with full remote control, IR, PoE).
- ▶ Outdoor cap.

Model
Eye-1



Model
Parkingbnb ZC-1

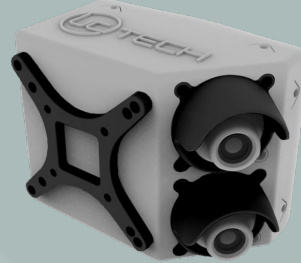

Model
Eagle-8



	EYE-1	PNB ZC-1	EAGLE-8
RECOGNITION DISTANCE (m)	48	25	432
RECOGNITION ACCURACY (av.)	99.4%	99.8%	99.3%
FRAMERATE	30 FPS	25 FPS	30 FPS
NON-STANDARD LPR	Yes	Yes	Yes
MAX VEHICLE SPEED	50 km/h	50 km/h	50 km/h
CMOS	HD	HD 5MP, RGB	4MP, RGB
IP RATING	IP66	IP54	IP66
SYSTEM CONNECTION	WiFi, LAN	WiFi, LAN	LAN
POWER SUPPLY	12VDC, 3A, PoE	110~220VAC, 5A, PoE	12VDC, 3A, PoE
MATERIAL		ABS, aluminum	
OPERATING TEMPERATURE (°C)	-40 ~ +70	-25 ~ +55	-40 ~ +70
MAXIMUM IR DISTANCE (m)	25	N/A	100
ZOOM (optical/digital)	4x / 16x	adjustable	25x / 16x
EDGE COMPUTER	N/A	128 NVIDIA CUDA® cores, 4-core ARM	N/A
WEIGHT (g, net)	500	1,150	2,400



AVR AI Camera

VIDEO SETTINGS:

- ▶ Compression: AI Coding, H.264H, H.264B, Smart H.265+, H.264, H.265, MJPEG (Sub Stream), Smart H.264+
- ▶ Backlight compensation: Backlight compensation (BLC), Highlight compensation (HLC), Wide dynamic range (WDR)
- ▶ Day/night: Auto (ICR), Color, B/W
- ▶ Streaming: 3 streams
- ▶ Bit rate: CBR/VBR
- ▶ White balance: Auto, Indoor, Outdoor, ATW, Manual, Sodium Lamp, Natural Light, Street Lamp
- ▶ Gain: Auto, Shutter Priority, Gain Priority, Manual



Double-side Spot Monitor

BAT-1 camera has 2 lenses with the opposite directions to recognize up to 4 parking spaces from 2 sides. The average recognition rate for vehicle license plates is 99%. Detection of vehicle type, color and make is available with 80% average accuracy. Each lens can be flexibly adjusted for better space coverage. The camera has an audio speaker that can be set up for automatic alerts or manual announcements. Up to 6 cameras can be connected via PoE daisy chain. LED indicator can be used to indicate occupied or unoccupied parking spaces as well as special-purpose spaces, s.a. for disabled or electric vehicles, other colors and flashing are supported.

SPECIFICATIONS:

Image Sensor	: 1/2.8" Progressive CMOS
WDR	: 120dB Super WDR
Shutter	: 1/1000000s~1s
LED Indicator	: Red (occupied), Green (available), Blue (disabled, EV parking)
Lens	: 2.8mm*2@F1.6
Field of View	: H106/D127/V56
Angle Adjustment	: Pan (0 to 60), Tilt (0 to 30)
Image Resolution	: 2048x1536
Compression	: H.264
Bit rate	: CBR/VBR s
Settings	: Brightness, Contrast, Saturatin, Sharpnes
Occupancy accuracy	: 99.9%
Ethernet	: 2*RJ45
Audio	: yes
Protocols	: TCP/IP,HTTP(S),RTSP,DDNS,SNMP,UPnP
Temperature	: 40 to 60 (celsius)
Humidity	: 5~90%
Power	: PoE (48V~0.3A)*2, DC12V
IP Rating	: IP65
Weight	: 500g

Model
BAT-1



Double-side Spot Monitor

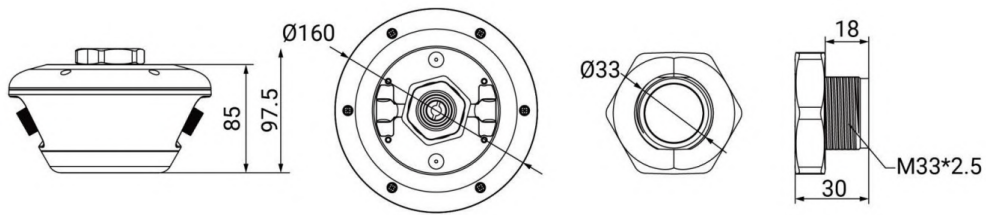

Can be connected with occupancy screen



Region : 1 Name : Name 1 Occupied	Region : 2 Name : Name 2 Unoccupied	Region : 1 Name : Name 1 Unoccupied	Region : 2 Name : Name 2 Unoccupied	Region : 3 Name : Name 3 Unoccupied	
License Plate	Plate Color	Vehicle Color	Vehicle Type	Vehicle Brand	Time
WP7152	White	White	Van	-	2024-05-10 17:50:59

Digital Barrier Gate

Our next generation digital barrier gates are able to operate during extreme traffic loads in tough operating and climate environments. IP54, -25°C to 70°C operating temperature and UV blocking weatherproof coating making our gates versatile for most applications. A brushless DC motor ensures more than 3 million smooth operations during peak hours outperforming traditional boom barriers. The barrier gate has advanced anti-crushing protection: infrared anti-crushing, radar anti-crushing, and anti-crushing loop detector.

Model
BR-01

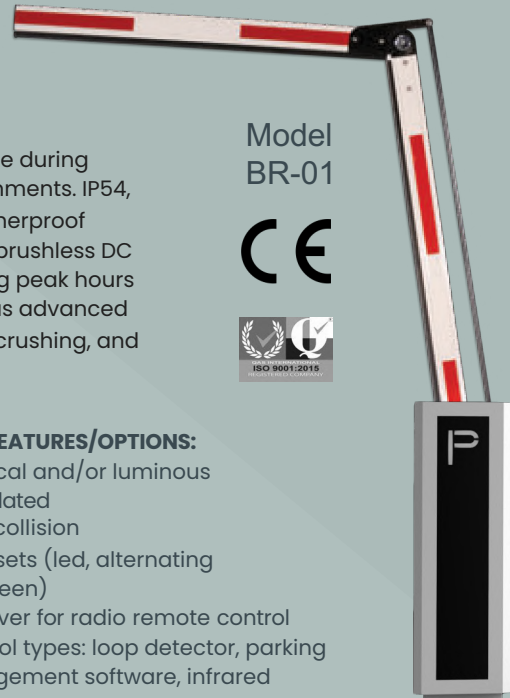

MAIN FEATURES:

- ▶ The P-type breathing light design can clearly display the operating status of the boom gate, which greatly improves the passing experience
- ▶ Adjustable opening speed to accommodate your traffic management needs: from ultra-fast to slow
- ▶ Automatic opening in case of power failure (adjustable with pressure springs)

BOOM FEATURES/OPTIONS:

- ▶ Elliptical and/or luminous
- ▶ Articulated
- ▶ Anti-collision
- ▶ Light sets (led, alternating red/green)
- ▶ Receiver for radio remote control
- ▶ Control types: loop detector, parking management software, infrared controller and manual control.

Parameter	Value
Input Voltage	AC220±10%, 50Hz, AC110±10%, 60Hz
Operating Voltage	DC 24V
Operating Temperature	-25°C ~70°C
Operating Humidity	≤95%
Motor Power	150W
Communication Interface	IO, TCP/IP
Lifespan	≥3,000,000 cycles
Protection Grade	IP54
Anti-crushing	Digital anti-crushing, infrared anti-crushing, radar anti-crushing, anti-crushing loop detector
Anti Collision Boom	Support
Radar	Optional
Height of Boom	930mm
Dimension (LWH)	385mmx340mmx1070mm

Boom Type	Boom Length	Operation Speed	Boom Material	Bumper Strip	Reflective Membrane
Articulated Boom	3m≤L≤5m	2.0s~2.5s	Aluminum alloy	Default Support	Red+White
Elliptical Boom	3m≤L≤6m	1.0s~5s	Aluminum alloy	Default Support	Red+White
Anti-collision Elliptical Boom	3m≤L≤4.3m	2.0s~4s	Aluminum alloy	Default Support	Red+White
Luminous Boom	3m≤L≤5m	2.0s~4s	Aluminum alloy	Default Support	Red+White

Digital Barrier Gate

MOTOR CHARACTERISTICS:

- ▶ Energy saving concept
- ▶ Powerful brushless 24V DC motor
- ▶ Planetary multistage gear

LOOP DETECTORS:

- ▶ 3 built-in single channel loop detectors
- ▶ Configurable holding times
- ▶ High or low frequency setting
- ▶ 8 sensitivity levels

FUNCTIONAL:

- ▶ 6 multi-functional and configurable output relays (max 24V/1A)
- ▶ Adjustable opening angle ($> 55^\circ$ in steps of 5°)
- ▶ Arm connector is usable left/right without modification
- ▶ Service counter
- ▶ Pre-warning settings for arm movement
- ▶ Directional logics programming
- ▶ Extensive error messaging (fault finding)



Barrier Gate

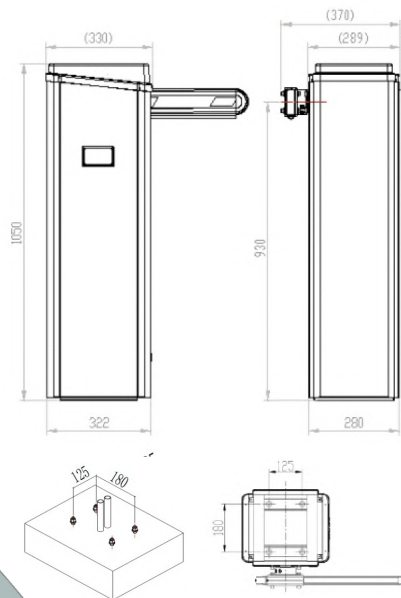

Exit-only Multi-payment Kiosk

Collector-1 Exit-only Multi-Payment Kiosk supports access control at the exit of car parks. It has a revolutionary look that allows for an ergonomic integration with any site. The attractive look and feel is combined with the latest technology. Comprehensive multi-payment setup allows visitors to settle parking and mobility services using the latest cashless options, s.a. credit cards, Apple/Google Pay, QR-driven payments and transportation cards. 9" LCD display, online video intercom, thermal receipt printer and built-in vehicle detector are among the add-on features to ensure the best customer experience. The kiosk is connected to the IoT cloud platform and back-up on-site mini-server for fully unmanned real-time remote control. Payments can be sent and adjusted in real-time to avoid traffic congestions and labor involvement.

SPECIFICATIONS:

Computer	: Industrial PC (1.6GHz Pentium Processor)
Reader	: QR code scanner
Ticket Printer	: Thermal printer. Printing 80mm, 32 bit color. Has auto-cutter.
Capacity	: 1000+ tickets, design can be customized
Video intercom	: VoIP based module with speaker and microphone
Season Cards	: Mifare (ISO14443A) card reader. Optional multiformat reader
Compliance	: ISO 9001:2015, ISO 14001:2015
Additional Options	: Integrated with Vehicle Recognition, Mid range UHF reading (passive cards or tags), Long range UHF reading (active cards)
3rd Party Integration	: On request
Working Voltage	: DC12V±20%
Operation Current	: <4A
Power Consumption	: <50W
Relative Humidity	: ≤95%, no condensation
Communication Interface	: TCP/IP
IP Rating	: IP54
Dimensions (mm)	: 178mm223mm1400mm
Installation Type	: Vertical
Weight (kg)	: 25
Design Life	: ≥100,000 hours
Mean Time Between Failure	: 5000 hours
Screen Type	: 9-inch LCD
Cabinet Material	: Sheet Metal + Glass Panel
Overall Height	: 1,400mm
Camera Height	: 1,350mm
Voice Intercom Button Height	: 1,000mm



Model
Collector-1

Exit-only Multi-payment Kiosk

ENCLOSURE AND SCREEN:

- ▶ Industrial grade carbon steel body with metal spraying process for strong corrosion and weather resistance
- ▶ Delicate and durable buttons
- ▶ Configurable LED side lights
- ▶ 9" LCD display comes with high-strength tempered glass which is 3-5 times stronger than ordinary glass
- ▶ The surface of the display is clear under strong light with extra-bright LCD technology

FUNCTIONAL:

- ▶ Fully programmable customizable white-label multi-language interface is available upon request
- ▶ Support picture-in-picture during video calls using intercom, so both customer service staff and customer can be displayed in one screen
- ▶ 2 seconds to connect video
- ▶ Low latency: video delay is less than 1 second, audio delay is less than 300 ms
- ▶ Intelligent noise reduction technology improves sound clarity by 30%



Gateless-type Multi-payment Kiosk

Collector-K Gateless-type Multi-Payment Kiosk supports access control at car parks with gateless access. It has a revolutionary look that allows for an ergonomic integration with any site. The attractive look and feel is combined with the latest technology. Comprehensive multi-payment setup allows visitors to settle parking and mobility services using the latest cashless options, s.a. credit cards, Apple/Google Pay, QR-driven payments and transportation cards. 9" LCD display, online video intercom, thermal receipt printer and built-in vehicle detector are among the add-on features to ensure the best customer experience. The kiosk is connected to the IoT cloud platform and back-up on-site mini-server for fully unmanned real-time remote control. Payments can be sent and adjusted in real-time to avoid traffic congestions and labor involvement.

SPECIFICATIONS:

Computer	: Industrial PC (1.6GHz Pentium Processor)
Reader	: QR code scanner
Ticket Printer	: Thermal printer. Printing 80mm, 32 bit color. Has auto-cutter.
Capacity	: 1000+ tickets, design can be customized
Video intercom	: VoIP based module with speaker and microphone
Season Cards	: Mifare (ISO14443A) card reader. Optional multiformat reader
Compliance	: ISO 9001:2015, ISO 14001:2015
Additional Options	: Integrated with Vehicle Recognition, Mid range UHF reading (passive cards or tags), Long range UHF reading (active cards)
3rd Party Integration	: On request
Working Voltage	: DC12V±20%
Operation Current	: <4A
Power Consumption	: <50W
Relative Humidity	: ≤95%, no condensation
Communication Interface	: TCP/IP
IP Rating	: IP54
Dimensions (mm)	: 178mm223mm1400mm
Installation Type	: Vertical
Weight (kg)	: 25
Design Life	: ≥100,000 hours
Mean Time Between Failure	: 5000 hours
Screen Type	: 9-inch LCD
Cabinet Material	: Sheet Metal + Glass Panel
Overall Height	: 1,400mm
Camera Height	: 1,350mm
Voice Intercom Button Height	: 1,000mm



Model
Collector-K

Gateless-type Multi-payment Kiosk

ENCLOSURE AND SCREEN:

- ▶ Industrial grade carbon steel body with metal spraying process for strong corrosion and weather resistance
- ▶ Delicate and durable buttons
- ▶ Configurable LED side lights
- ▶ 9" LCD display comes with high-strength tempered glass which is 3-5 times stronger than ordinary glass
- ▶ The surface of the display is clear under strong light with extra-bright LCD technology

FUNCTIONAL:

- ▶ Fully programmable customizable white-label multi-language interface is available upon request
- ▶ Support picture-in-picture during video calls using intercom, so both customer service staff and customer can be displayed in one screen
- ▶ 2 seconds to connect video
- ▶ Low latency: video delay is less than 1 second, audio delay is less than 300 ms
- ▶ Intelligent noise reduction technology improves sound clarity by 30%



Dynamic 43" LCD Signage

UrbanChain Group offers state-of-the-art solutions to revolutionize the parking and mobility industry. Our digital signage is a game-changer in delivering real-time information to customers. Whether you need to showcase real-time parking occupancy by vehicle type, EV charger availability, dynamic pricing, or advertisements, our solutions have you covered. Our weatherproof LCD signage is designed for optimal performance and visibility in extreme outdoor environments. Fully customizable software allows seamless integration with your branding and operational logic. Constructed with industrial-grade materials and equipped with advanced display settings, our digital signage ensures reliable operation and exceptional clarity, even under the harshest conditions.

KEY CHARACTERISTICS:

- ▶ 43/ 55/ 65 inch outdoor LCD Display, Non TOUCH
- ▶ Outdoor using with waterproof, wide temperature glass for heat-resisting
- ▶ Protection: IP65, vandal proof
- ▶ Resolution: 1920*1080. Brightness: 3000nits.
- ▶ Computer: Linux system, 2G RAM+16G ROM
- ▶ WiFi, LAN or 4G driven connection
- ▶ Wide range of audio and video inputs like SD card and USB Flash and outputs such as HDMI/VGA/DVI/USB/RJ45
- ▶ Comprehensive fan cooling system
- ▶ Waterproof high quality 2*10W speaker
- ▶ Enclosure: 1.5mm galvanized steel sheet, surface spray outdoor special powder, protection capacity more than 7 years
- ▶ Wide range of audio and video inputs including SD card, USB flash, and outputs including HDMI/VGA/DVI/USB/RJ45
- ▶ Comprehensive fan cooling system
- ▶ Power supply: AC100v-240v, consumption 400W

Model LD-1

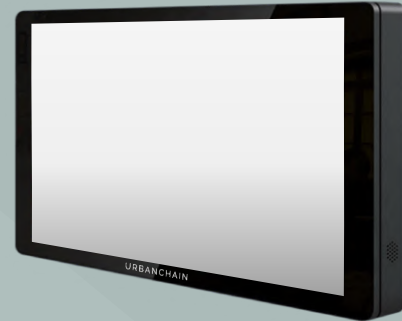

Dynamic 43" Outdoor LCD Signage

Processor and Software:

- ▶ Quad-core CPU, 2GB RAM, 16GB storage
- ▶ Quad-core CPU, 2GB RAM, 16GB storage
- ▶ Operating System: Linux or Android
- ▶ Supported Video Formats: MPEG-1, MPEG-2, MPEG-4, H.263, H.264, VC1, RV, etc. up to 1920x1080p
- ▶ Audio Formats: MP3/WMA
- ▶ Image Formats: JPEG, PNG, BMP



32" In-/Outdoor LCD Screen

The IOLD-3 LCD display revolutionizes the initial engagement experience with visitors. Offering a fully customizable white-label interface, it caters to all your specific needs. Greet your customers with personalized messages, details about their parking session, current promotions, special offers, and information about payments for parking, EV charging, or even nearby shops and restaurants, including discount redemptions. Content can be displayed in various formats such as text, images, image sliders, videos, and can include QR codes for engagement tracking.

SPECIFICATIONS:

System

CPU	I3 4000, others available upon request
RAM	4GB
Memory	128GB
OPTIONAL Interface	USB/SD card/Ethernet USB, DF, LAN, VGA (3G/4G optional)

Display parameter

Panel brand	
Aspect ratio	16:9
Resolution	1920X1080P
Brightness	1500-2500CD/M ²
Contrast ratio	5000:1
Response time	5MS
Dot pitch	0.53 (H) X0.53 (V) MM
Color	16.7M
Viewing angle	89/89/89/89 (MIN.) (CR≥10)
Standard size	32/43/49/55/65 or customized

Operating environment

Temperature	-20°C TO 50°C
Humidity	10~90%RH
Input voltage	AC 100-240V
IP rating	IP55 (indoor), IP65 (outdoor)

Shell parameter

Color	White/Black/Silver/Customized
Structural material	Sheet metal shell + aluminum alloy frame
Appearance treatment	Oxidation drawing/spraying
Screen	Tempered glass
Installation	Outdoor wall-mounted

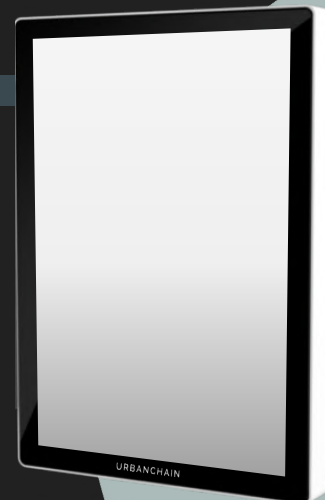

Model
IOLD - 3

32" In-/Outdoor LCD Screen

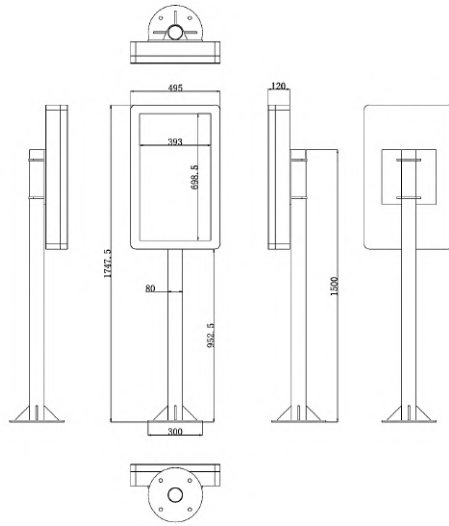

Gate Controller

EBIS-3 is a wireless or LAN-driven gate controller that uses dry contact for operations. It can control any type of parking barrier gate. Seamless performance in parallel with gates of 20+ world's largest barrier manufacturers we have tried so far. No interruption to existing hardware or gate controllers.

SPECIFICATIONS:

- ▶ Average response time is <1 sec;
- ▶ Can connect to any existing parking gate;
- ▶ Wireless connection: parking gates can be controlled remotely through relays;
- ▶ Size and designed is easily customizable;
- ▶ Can be used to control other devices remotely, i.e. spotlights.
- ▶ Power consumption: 220 VAC, 2A;
- ▶ Size: 50x80x30mm;
- ▶ Wireless connection: Wi-Fi 802.11 b/g/n;
- ▶ Operating temperatures: -20 °C to +55 °C

Model EBIS-3



Gate Controller

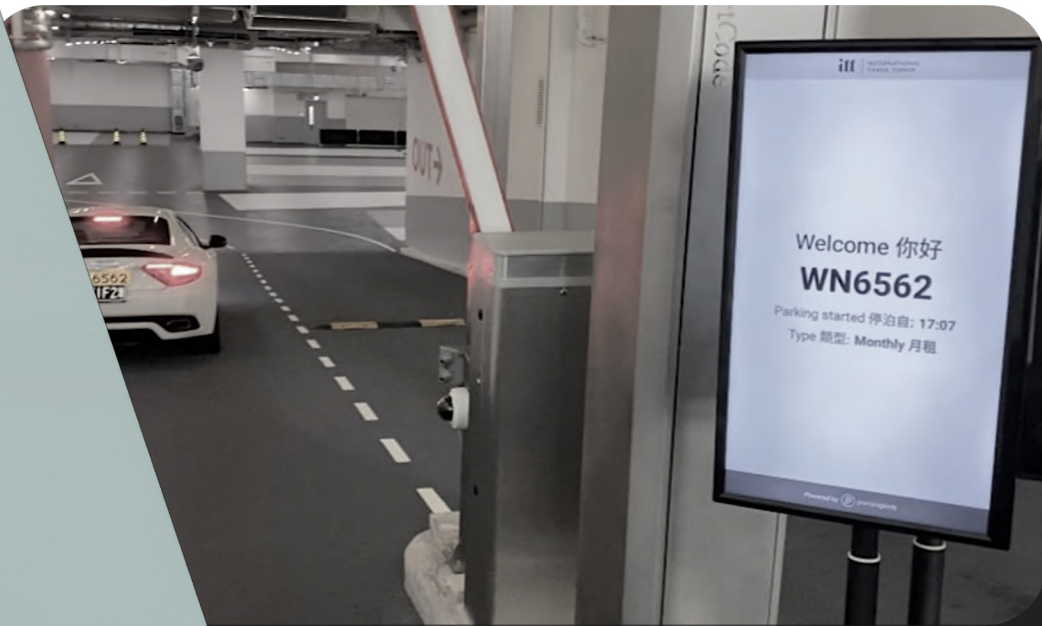
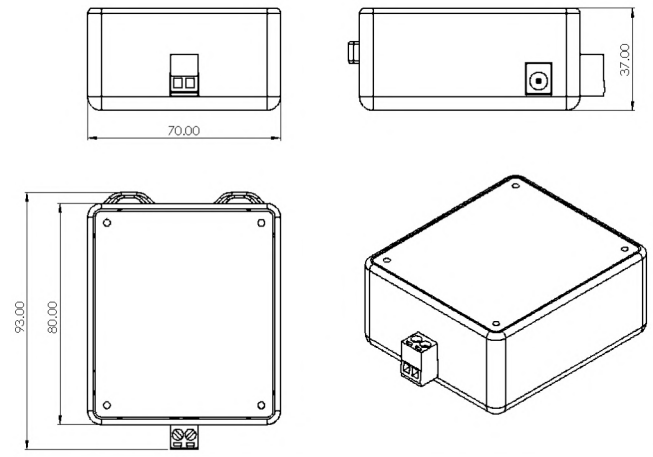



EV Charger

Model Todd CP1
(7kW ~ 11kW)

Standard Features

 Convenient and quick: Plug & charge

 Safety - OPEN solution available for UK

 IP65, weather proof outdoor charger

 IEC 62196-2 Type 2

 Anti-UV treatment & yellow resistance

 Wi-Fi & Bluetooth + APP control



Model No.	Todd CP1-07	Todd CP1-11
Input voltage	230VAC±10%	400VAC±10%
Frequency	50-60Hz	
Amperage	32A	16A
Max Power Out	7kW	11kW
Dimensions	220x220x95mm	
Operating temperature	~30 – 50	
Humidity	Up to 95% non-condensing	
Interface	IEC 62196-2 Compliant, Type 2	
Safety	IEC 61851-1, IEC 61851-21-2	
Protection	UVP, OVP, RCD (DC 6mA), SPD, Ground Fault Protection OCP, OTP, Control Pilot Fault Protection	
Cable length	5m Standard Cable (7m Optional)	

Optional Features

 3-ph & 1-ph compatible
Load balancing function w / CT Clamp

 IEC 62196-2 Type 1 connector

 OCPP 1.6J

 NFC Authentication

EV Charger



Parking U-lock

The UL-1 Parking Lock is a versatile solution for effortless management of your parking spaces. Designed for a range of applications including parking reservations, prevention of illegal parking, and VIP space management, this robust device ensures smooth operation. Constructed from high-strength steel, the UL-1 can withstand the weight of most passenger vehicles, including cars and light trucks, supporting up to 3 tons.

SPECIFICATIONS:

Feature	Value
Dimension	480*460*100mm
Net weight (without battery)	3.5kg
Waterproof grade	IP67
Materials	ABS G30, 8mm thickness
Environment Temperature	-10°C~+70°C
Communication	WiFi / Bluetooth / Lora
Remote frequency	433 MHZ
Remote control distance	50M
BLE	38m, frequency: 2.4G
Max. Gateway simultaneous connections	1
Bear load	3T
Battery	12V DC, rechargeable battery
Average battery life	Up to 6 month on a single charge
Additional security	tamper-resistant design, reinforced locking mechanism
Alarm	120dB alarm for unauthorized access
Applications	Residential, commercial and public parking facilities

Model UL-1



Parking U-lock



460MM

— 480MM —



460MM

— 100MM —



Admin portal

COST-EFFICIENT & DATA-DRIVEN OPERATIONS

MAKE BEST USE OF AI, BIG DATA AND INTEGRATION TO CENTRALIZE AND AUTOMATE PROPERTY MANAGEMENT

REMOTE CONTROL

In today's push for automation, parking operators are still heavily dependent on manual operations, resulting in extremely low profit margins. If you still have staff at parking lots, customer service desks, cashier offices, and control rooms at each location, we have good news for you: our IoT system can automate most of your manual tasks. Here are some impressive numbers we are proud of:

1. Our system operates on 70% fewer devices on average compared to traditional parking vendors, leading to lower maintenance costs, reduced electricity consumption, and less risk of equipment failure.
2. All our devices are internet-connected and feature multi-layer auto-reset algorithms, reducing the need for on-site repairs by over 90% on average. Even if reconnection issues arise, our engineers promptly respond to real-time alerts. Internet disconnection won't disrupt your operations as our backup mini local server ensures seamless functionality. Mobile app users will continue to enjoy touchless access to your parking lots with the latest data available on the local server. Our routers also support dual SIM cards or multi-operator functions to ensure new app members enjoy a seamless experience.
3. With remote control capabilities, your staff won't need to manually operate gates, payment machines, or redemption devices. We help our clients reduce monthly operating costs by an average of JPY 750,000, maintaining smooth, uninterrupted operations and boosting your business's profitability.

Remote gate control
Open and close gate remotely

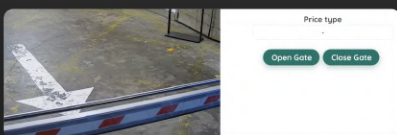

Live streaming
Enable 24/7 remote monitoring



Payment kiosk control
Send payment request to kiosk remotely with custom amt

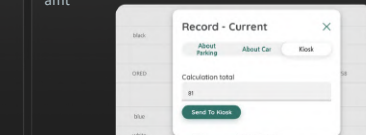

Parking history edit
Edit real-time parking records
Cross check with captured car photos

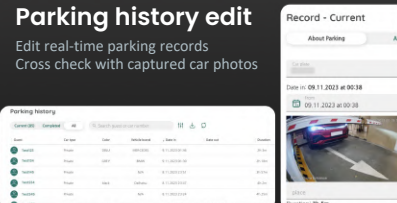

Payment at counter
Alternative way for payment

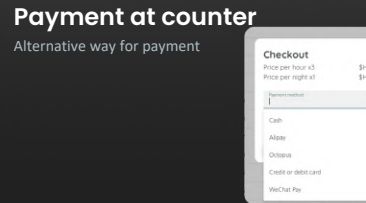

Master account
Manage multiple sites in one go

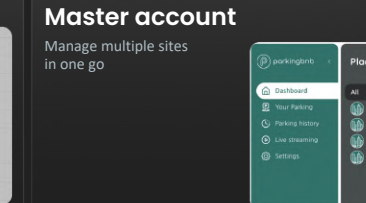

The portal is available in the following languages:



Admin portal

LEARN, OPTIMIZE, AUTOMATE

Your journey to cost reduction doesn't end with the remote control of your facilities. Every device and software provided by UrbanChain Group generates vast amounts of real-time data. Our AI algorithms, combined with our team of industry experts, continually analyze these data insights to develop profit-boosting strategies in both cost reduction and revenue generation. After integrating our AI cameras, it takes just 1-2 months to produce a comprehensive report with data-driven recommendations. These insights will help streamline your operations, optimize space management and pricing, and enhance your revenue with improved user experiences and new revenue opportunities.

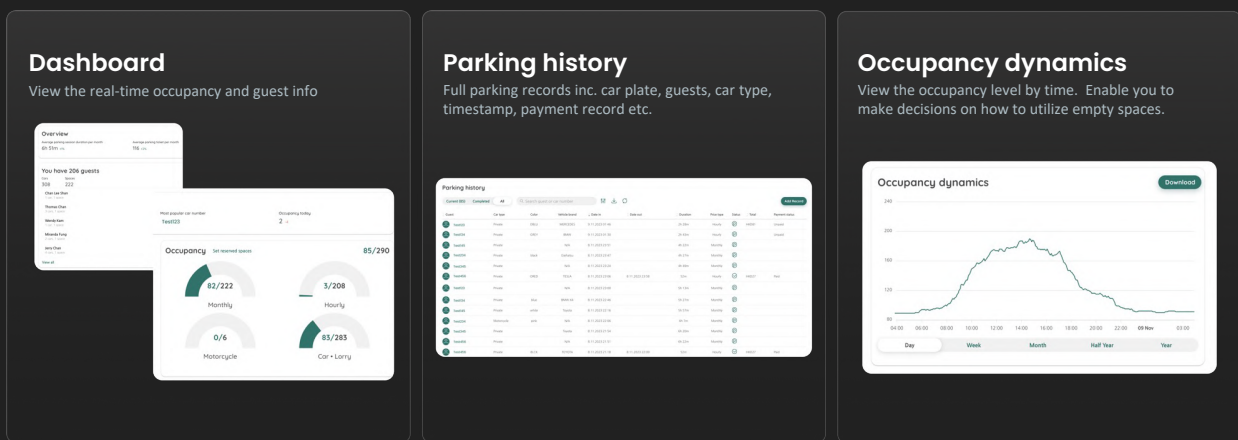

CENTRALIZE & MONITOR

Implement these solutions across all your parking lots and properties. Say goodbye to control rooms, cashier offices, and customer service desks. With everything managed from a single central location—whether citywide, prefecture-wide, or globally—our web-based, cross-platform admin portal makes it possible. We offer customized role management and real-time activity logs, enabling staff to access specific modules of the portal based on their role and departmental position. This platform is not only for asset management but also a productivity tool to better manage your staff and receive real-time alerts for any illegal activities.

ALL INCLUDING BUT NOT LIMITED TO:

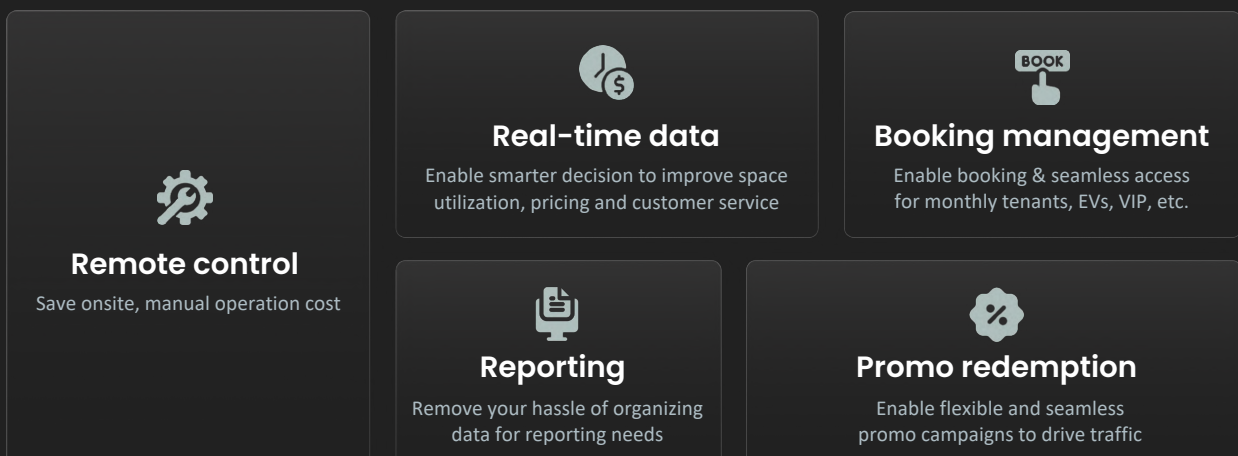

01 MOBILITY IN A POCKET

SIMPLE, LIGHT, SMOOTH AND SEAMLESS

At UrbanChain Group, we prioritize our users' feelings in every consumer interface we build. For us, the perfect user experience and user interface reflect an ideal emotional response. Every mobile interface we design must be simple, light, smooth, and seamless.

TIME, MONEY AND NATURE SAVING MOBILITY ECOSYSTEM

UrbanChain Group's solutions aim to maximize the efficiency of existing urban infrastructure, with a clear understanding that people are the driving force behind this realization. Urban citizens are motivated by savings—time is money, and money buys time. We design mobile solutions that respect our clients' and their end-users' time, allowing them to save money and focus on invaluable aspects like family and nature. Statistics show that one-third of road traffic is caused by drivers searching for parking, while parking lots are less than 50% occupied on average throughout the day. Millions of people are late for work, school, and appointments. Understanding the critical role of mobility in cities worldwide, UrbanChain Group is committed to reshaping the way people move by connecting individuals, vehicles, and places efficiently and seamlessly. Our mobile solutions are designed to be highly affordable, ensuring everyone can carry them in their pocket daily.

BETTER INSIGHTS, MAXIMAL ROI

We invite every industry player and government organization to join us in revolutionizing the future of smart mobility. We believe that motivation drives delivery, and our clients and partners need to achieve their KPIs. All our solutions are crafted to maximize our clients' return on investment, whether in monetary terms or time savings. The key to boosting ROI is data—the better the insights, the better the outcomes. Our mobile solutions ensure our clients receive the right real-time data to optimize space utilization, customer retention, and user experience.

URBANPASS



White-label web app. We can deliver to you the same with your logo and branding.

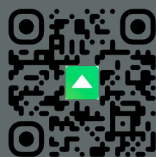

parkingbnb



Native app to bring traffic to your parking lots.

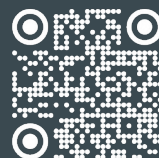

Mobile apps



駐車完了

車	名古屋301わ5838
開始時間	9:45, 17 May 2024
期間	15分
駐車場	¥50
EV充電	¥50
1時間無料	-¥50
初回	-¥50
金額	¥0 ¥100

02 TOUCHLESS PAYMENTS

PAY BY DRIVING OUT

Imagine paying for parking, EV charging, shopping, dining, and other services without visiting a cashier. Forget tapping credit cards, using IC cards, and scanning QR codes. Simply drive your car out of the parking lot, and the payment will be settled automatically. UrbanChain Group transforms your car into a credit card with our automated vehicle recognition system. Your car's license plate becomes your credit card number. All you need is a one-time registration in a web app: scan a QR code instead of downloading another app, input your phone number for one-time registration, and connect your preferred payment method. This is the future, and it's what you need to make your customers happy.

SCAN & PAY

Transitioning to a fully seamless payment experience takes time. Sometimes your parking lot visitors are in a rush, and filling out even simple data might raise privacy concerns. In such cases, Scan & Pay is your solution: users just need to scan a QR code, input the last four digits of their car plate number, and pay via Apple/Google Pay or credit card. Eventually, they'll realize that one-time registration is easier, but give them time to adjust.

IN CASE OF CONNECTIVITY APOCALYPSE

What if your customer runs out of battery, forgets to pay for a SIM card, or can't get a signal in the basement floor of the car park, or if city-wide connectivity is down? Our ultra-slim multi-payment kiosk mentioned in sections 5 and 6 is your reliable backup.

03 AUTOMATIC DISCOUNT REDEMPTION

AI-DRIVEN RECEIPT RECOGNITION

Statistics show that shopping malls lose up to 50% of their customers due to busy customer service desks where visitors queue for discount redemptions. Often, it's a hassle just to find these desks. By embracing the power of AI, you can reduce visitor churn by allowing them to simply scan receipts with their smartphone camera. Our algorithms will securely identify the information on each receipt and apply the discount automatically upon exiting the parking lot.

REAL-TIME DATA SUPER POWER

The information from receipts is fed directly to the admin portal, allowing your marketing department to monitor promotion utilization and efficiency in real-time. This enables you to set up effective discount offers and help your tenants maximize traffic and retarget their visitors. Not a shopping mall owner? Don't worry, we can help you connect with shops and restaurants around your parking lot.



Mobile apps

04 PROMOTIONS

RELEASE, TRACK, PERSONALIZE

In a world saturated with ads and promotions, how do you stand out? Data is your best advisor. UrbanChain Group supports the entire customer journey, from deciding which area to visit to selecting the exact shop or restaurant. We collaborate with your marketing team to collect, filter, and analyze data, run experiments, and choose the best action plan to deliver a personalized experience to your visitors.

SHOPPING DIRECTORY

Why spend money on bulky kiosks and banners with poor UX/UI for information? Simplify and make it accessible on the go for your customers while saving a substantial amount of money. A shopping directory in a white-label web interface digitizes the retail experience. Comprehensive algorithms for directory navigation, smart search and filtering, and smooth integration with receipt recognition, all in a user-friendly interface. Avoid the extra costs and hassle of updating information through your software vendor. Our easy-to-use admin platform enables your marketing staff to keep customers up-to-date effortlessly.

INDOOR NAVIGATION

Shopping mall visitors often reduce their time spent due to constant navigation issues, while shops and restaurants struggle to attract customers. The revolution is here: real-time indoor navigation in a web interface without installing a single device. Enhance visitor navigation with non-intrusive targeted promotions.

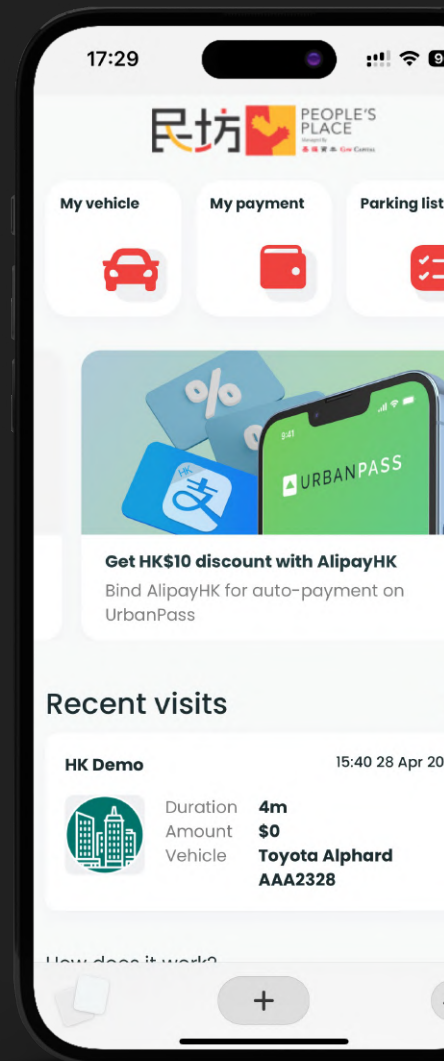

05 E-BOOKING & EV CHARGING

COMFORT AND SECURITY

One of the biggest stressors for drivers is finding an available parking space, taking an average of 20 minutes in any big city. Everyone deserves peace of mind, and UrbanChain Group has the perfect solutions. Our real-time occupancy feature, available in our apps and displayed on digital signage, and our space reservation system ensure convenience. Whether it's VIP parking, spaces for disabled, EV charging spaces, or unloading bays, our booking interface makes management easy. The booking function not only brings convenience but also enhances security. Occupancy-based parking ensures EV charging spaces aren't occupied illegally, and parking U locks guarantee smooth parking for VIP customers at all times.

BE EV FRIENDLY

In the era of rapid electric vehicle growth, you don't want to be the last to accommodate demand and recurring visits. While EV chargers can be bought directly from Amazon, UrbanChain Group offers a comprehensive integrated solution that connects EV charging with parking and retail. Visitors can pay for parking and EV charging in one go, with automatically applied discounts.

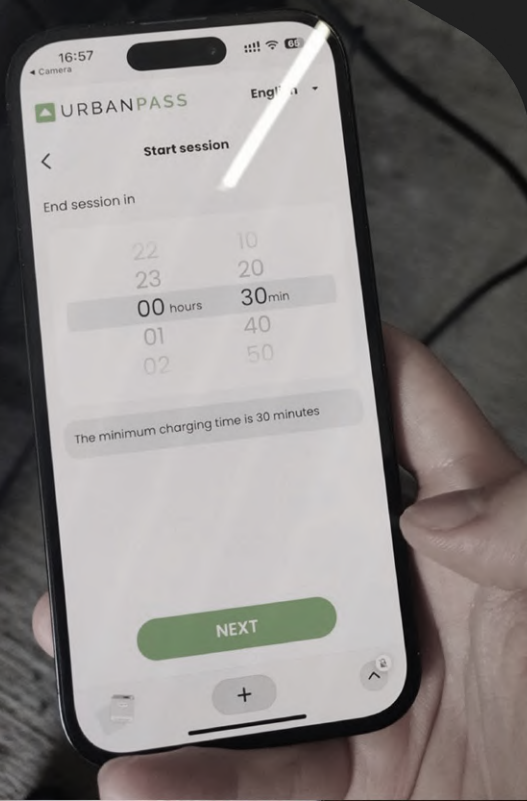

The Ultimate Future

01 DYNAMIC PRICING

IT IS ALL ABOUT THE SUPPLY AND DEMAND

Want to lead the real estate and mobility industry? Winning maximum demand is key. UrbanChain Group provides the winning tool: dynamic pricing. Leveraging our vehicle recognition technology, we can recommend the optimal pricing at any given time. While setting up dynamic pricing takes time, its counterpart, zonal pricing, offers an immediate revenue boost. By using an additional AI camera, you can implement different pricing for different floors or zones. It's highly affordable and can be integrated with occupancy sensors. Offer fairer options to your visitors while increasing your revenue—a win-win.

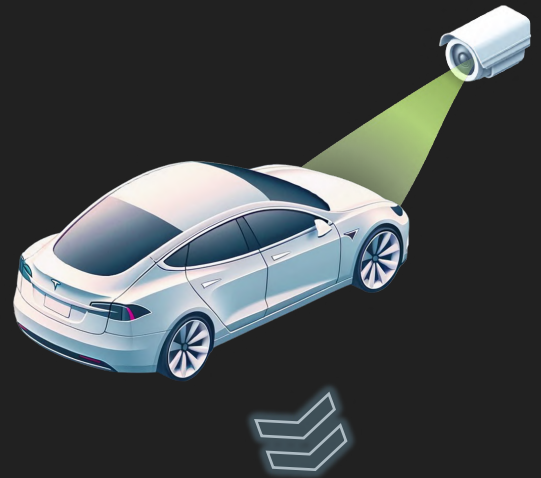

02 MOBILITY HUB

"PARKING LOT" IS A DEFINITION OF THE PAST

Every square meter costs money, but how much revenue can you generate from it? Don't limit your parking lot to just parking cars. We can transform it into a mobility hub by integrating a mobility ecosystem into your space: car sharing, e-mobility, delivery zones, EV charging, vending machines, digital advertisements, car services, smart lockers, and more!

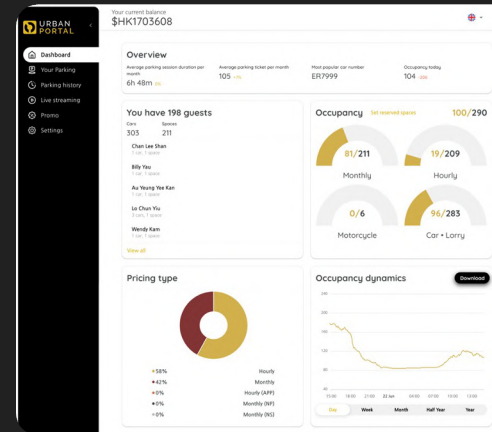

About us

We are your strategic partner in empowering next-generation parking & mobility experience

WE HELP

Property owners to improve utilization of parking and property spaces, and solve key operational challenges

Visitors to access destinations with better convenience and value

OUR PRESENCE

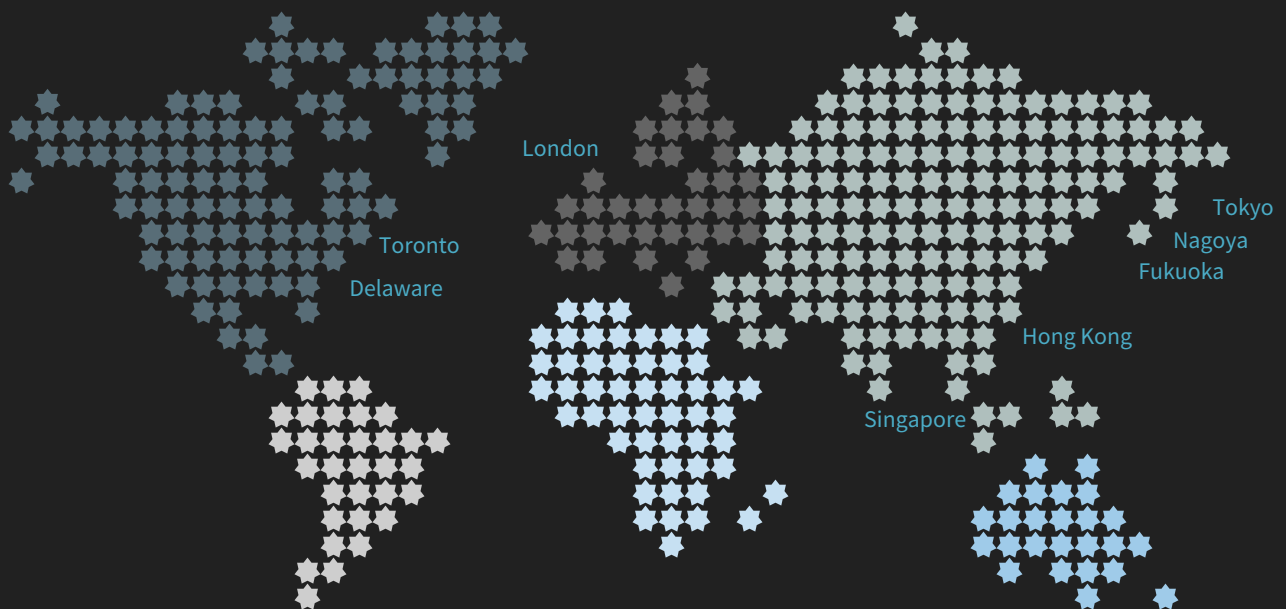

URBANCHAIN

URBANCHAIN GROUP CO., LTD

9F, 9F, 1 Chome-6-5 Marunouchi,
Chiyoda City, Tokyo 100-0005, Japan

T: +81 50 6867 0541

E: info@urbanchain.world

www.urbanchain.world

